

Fig 1.

Step 1. Insert a 1/8" x 1/4" washer into the recessed area on each side of the rear pivot block.

Step 2. Place the right rear suspension arm over the right side of the rear pivot block. Line up the holes in the arm with the holes in the pivot block and attach them by inserting an inner rear hinge pin, 'E' clip groove forward, from the rear all the way through both pieces. Install a 1/8" 'E' clip to the front end of the hinge pin.

© **IMPORTANT NOTE:** The lettering on the rear pivot block should face up. The two rear arms are different. Ensure that the arm marked 'R' is on the right, and the arm marked 'L' is on the left.

Step 4. Repeat steps 1 and 2 for the left rear suspension arm.

Step 3. Attach the rear pivot block to the rear pivot plate with four 4-40 x 3/8" flat head screws.

© **IMPORTANT NOTE:** Be sure that the pivot block is installed with the wider end to the rear.

Step 4. Holding the chassis upside down, insert the tab on the rear pivot plate under the rear part of the chassis, so that the pivot plate is flush with the chassis. Make sure that the four holes in the chassis line up with the four holes in the pivot plate. Secure the pivot plate to the chassis using four 4-40 x 1/2" cap head screws.

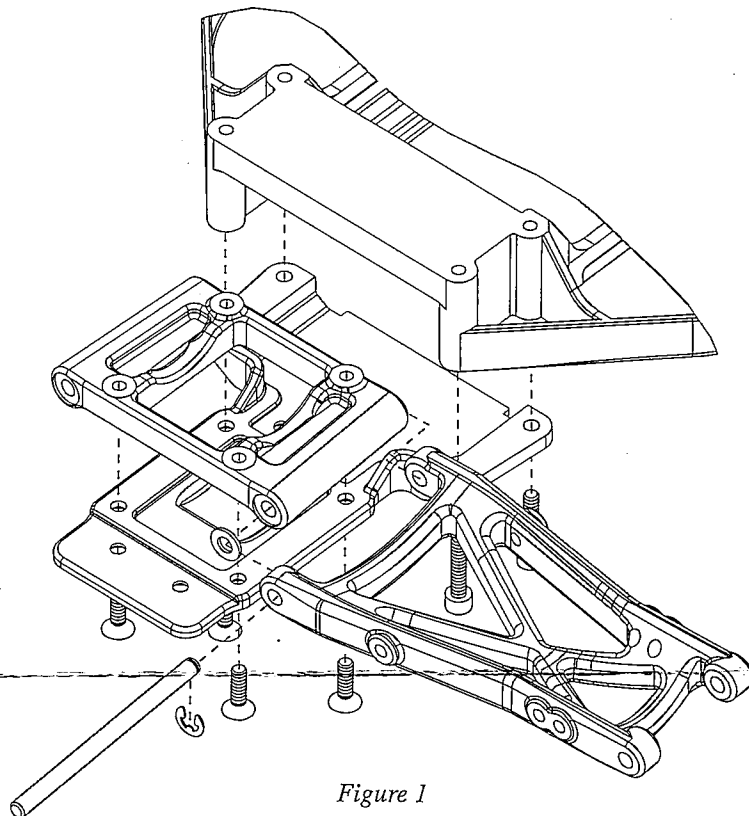

Figure 1

Fig 2.

Step 5. Press a 3/16" x 3/8" bearing into each side of the right rear hub.

Step 6. Thread a 3/8" ball stud into the 'A' hole in the rear hub, from the front (the side with the letter).

© **IMPORTANT NOTE:** Do not over tighten the ball studs.

Step 7. Place a "foam thing" over the ball stud.

Step 8. Repeat steps 5- 7 for the left rear hub.

Step 9. Slide a rear axle through the bearings in each rear hub, from the inside.

Step 10. Place a rear axle/gearbox spacer over each rear axle, against the outside bearing.

Step 11. Secure the rear axle and the spacer by inserting a 1/16" x 7/16" pin through the small hole in each of the rear axles. The pin should be centered in the rear axle.

Step 12. Place the right rear hub between the outer rails of the right rear suspension arm. Be sure that the ball stud is towards the front. Position a rear hub spacer between the hub and the suspension arm on each side of the hub.

Step 13. Insert a 1/8" hinge pin into the suspension arm, through each of the two spacers and rear hub. Secure the hinge pin with two 1/8" 'E' clips.

Step 14. Repeat steps 12 and 13 for the left hub and left rear suspension arm.

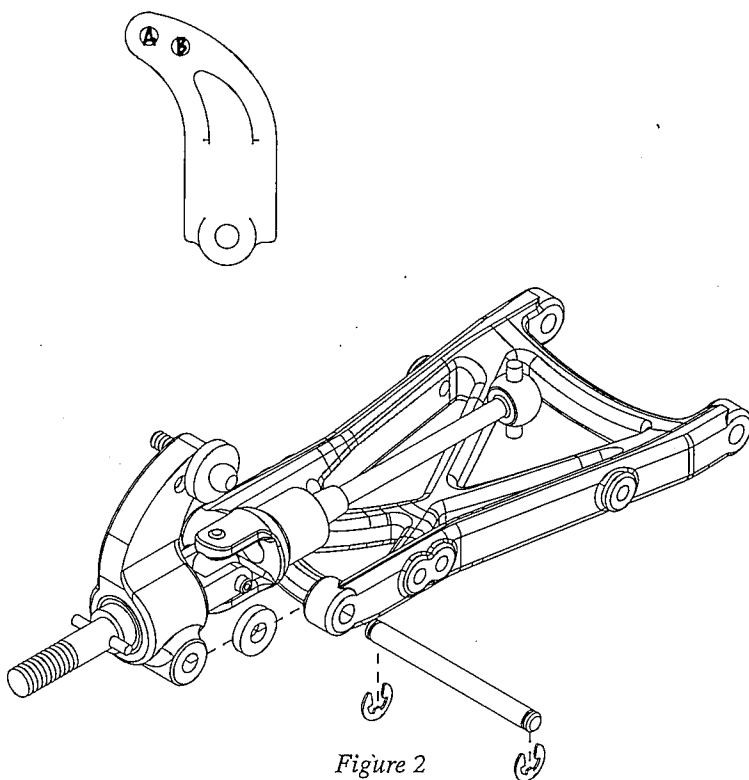

Figure 2



SET-UP SHEET



DATE: / /
 DRIVER:
 TRACK:

FRONT SUSPENSION

(CIRCLE OR CHECK CORRECT SETTINGS)

FRONT SPINDLE CARRIERS: 25°, 30°

TOE-IN / TOE-OUT: 1 °

FRONT RIDE HEIGHT: Just below arms level

FRONT CAMBER: \ominus 2 °

SWAY BAR: NO, YES - SIZE:

NOTES:

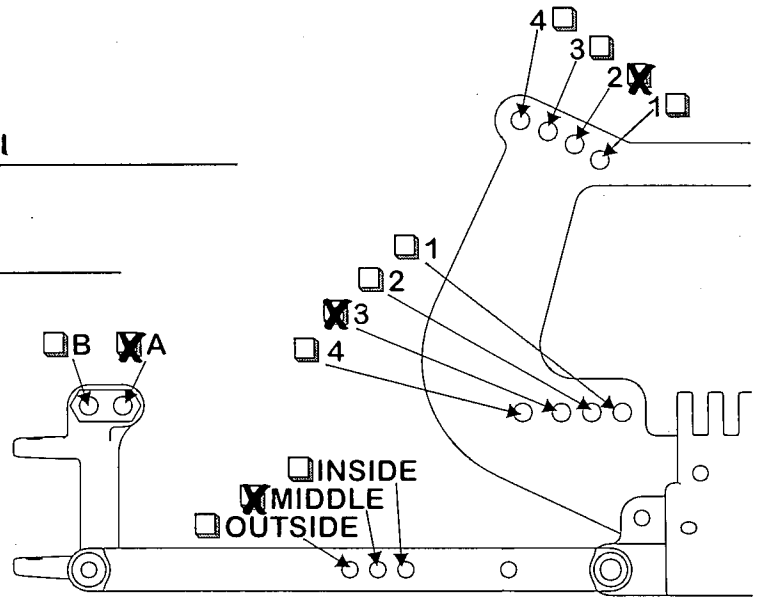

FRONT SHOCKS

OIL: 30
 PISTON: 57 DRILLED / STANDARD
 SPRING: Silver
 LIMITERS: INSIDE- , OUTSIDE-

REAR SUSPENSION

PIVOT SUPPORT: 0°, 2°

REAR RIDE HEIGHT: Just below dog bones level

REAR CAMBER: \oplus 2 °

SWAY BAR: NO, YES - SIZE:

NOTES:

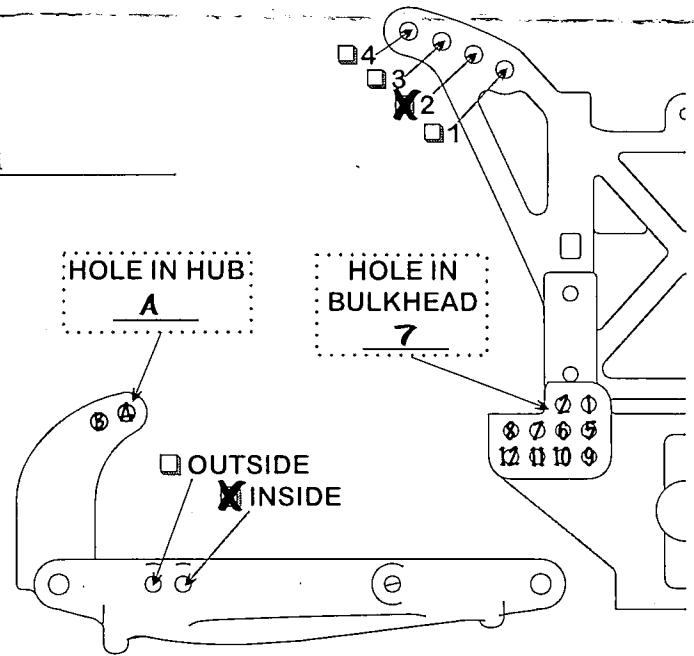

REAR SHOCKS

OIL: 30
 PISTON: 56 DRILLED / STANDARD
 SPRING: Yellow
 LIMITERS: INSIDE- 'A' , OUTSIDE- 'B'

TRANSMISSION & CHASSIS

HYDRA-DRIVE: NO, YES - FLUID: LIGHT, STD., HEAVY

FRONT TIRE: H.T., GOLD, SILVER

REAR TIRE: H.T., GOLD, SILVER

CHASSIS: SHORT, STANDARD, LONG, X-LONG

BATTERY: 6 CELL, 7 CELL BATTERY PLACEMENT: 1/4" back

TRANSMISSION: 2.19, 2.61

MOTOR:

PINION GEAR:

SPUR GEAR: